



# B-17F „MEMPHIS BELLE“

04297-0389

© 2008 BY REVELL GmbH & CO. KG

PRINTED IN GERMANY



## B-17F „MEMPHIS BELLE“

Die Boeing B-17 wurde im 2. Weltkrieg zum Synonym für die schwerbewaffneten strategischen Bomber obwohl sie mit 12.677 Maschinen noch längst nicht die am meisten gebaute Maschine dieser Art war. Ihren Namen „Flying Fortress“ erhielt sie von einem amerikanischen Journalisten nach dem Erstflug und er blieb ihr erhalten. Was in der Geschichte der B-17 meist unbekannt bleibt: Sie wurde zur Geburtsstunde der Checklisten - ohne die in der Fliegerei kaum noch Jemand auskommt. Der Anlass war ein Unfall während der Prototypenerprobung der zur Zerstörung der Maschine führte. Die Besatzung hatte vergessen die vom Cockpit aus zu bedienende Feststellvorrichtung der riesigen Quer- und Höhenrudern zu lösen. Um einem ähnlichen Fehler vorzubeugen führte Boeing die erste Checkliste ein. Die Boeing B-17F war auch die erste Flying Fortress die in Massenproduktion hergestellt wurde. Neben den 2300 Maschinen die bei Boeing gebaut wurden fertigte Vega in Burbank, Kalifornien 500 Maschinen und Douglas baute in Long Beach, Kalifornien weitere 605 B-17F. Die berühmteste Maschine aus dieser Baureihe war die bei Boeing gefertigte B-17F-10-BO die am 15. Juli 1942 ausgeliefert und am bei der 324th Bomber Squadron, 91st Bomber Group in Basingstow, England in Dienst gestellt wurde. Von ihrer Besatzung erhielt sie den Namen „Memphis Belle“, nach der Freundin des Piloten Lt. Robert K. Morgan. Ihre Berühmtheit resultierte aus der Tatsache das sie offiziell als erster Bomber der US Army Air Force in Europa 25 Einsätze überlebte und zum Star eines Hollywood Propaganda-Films von William Wyler wurde, der 1943 in die Kinos kam. In Wirklichkeit war es jedoch die B-17F-25-BO „Hell's Angels“ (41-24577) von der 365th Bomber Squadron; 305th Bomber Group die am 13. Mai 1943 dieses Ziel erreichte. Die „Memphis Belle“ hingegen flog ihren 25th Einsatz erst am 17. Mai 1943 bei einem Angriff auf die deutsche U-Boot Basis Lorient, Frankreich. Nach diesem Einsatz wurde die „Memphis Belle“ mit ihrer Besatzung in die USA beordert um mit ihrer Popularität für die Zeichnung von Kriegsanzügen zu werben und um die Moral der amerikanischen Arbeiter in den Rüstungsbetrieben zu heben. Vor und während der Tour durch die USA erhielt die „Memphis Belle“ zahlreiche Änderungen an ihrem Aussehen. Besonders die Namen der Besatzungsmitglieder wurden erst zu einem späteren Zeitpunkt angebracht. So hat der Modellbauer bei diesem Bausatz die Wahl unter verschiedenen Alternativen. Die „Memphis Belle“ ist die älteste B-17 die erhalten geblieben ist. Nach dem Krieg wurde sie von der Stadt Memphis „gekauft“ und unter freiem Himmel als Denkmal aufgestellt - was ihrem Erhaltungszustand nicht besonders förderlich war. Bei der „Restaurierung“ gingen dann auch noch die letzten erhalten gebliebenen Originalzeichnungen und Markierungen verloren. Am 29. September 2004 machte das National Museum der USAF von seinem Besitzrecht gebrauch und ordnete die Rückführung der „Memphis Belle“ nach Wright-Patterson AB an. Hier wurde die B-17F einer kompletten Restaurierung unterzogen wobei sehr viel Wert auf die originalgetreue Wiederherstellung aller Markierungen verwendet wurde. Heute ist die „Memphis Belle“ wieder der Öffentlichkeit zugänglich.

### Technische Daten:

Spannweite	31,63 m
Länge	22,78 m
Höhe	5,82 m
Motoren	4 x Wright Cyclone R-1820-97
Leistung	1 200 PS
Notleistung	1 380 PS
Leistung in 8 000 m	1 000 PS
Basisgewicht	15 876 kg
Startgewicht max.	29 484 kg
Reisegeschwindigkeit	297 km/h
Höchstgeschwindigkeit	526 km/h
Dienstgipfelhöhe	11 734 m
Bewaffnung	8 x 453 kg Bomben oder bis zu 24 x 45,3 kg Bomben 13 MG Kaliber 12,7 mm
Besatzung	10 Mann

## B-17F „MEMPHIS BELLE“

During the Second World War the Boeing B-17 became synonymous with the heavily armed strategic bomber even though with a total of 12677 aircraft built, it was not the most prolific aircraft of this type. It received its name „Flying Fortress“ from an American journalist after its maiden flight and never lost it. A fact that is mostly forgotten in the history of the B-17 is the introduction of Check Lists or Flight Reference Cards, without which almost no-one in modern aviation takes to the air. The reason for this was an accident during prototype testing which led to the aircraft being destroyed. The crew had forgotten to release a locking arrangement for the enormous rudder and elevator which was controlled from the cockpit. In order to prevent further mistakes of this nature Boeing introduced the first „Flight Reference Cards“.

The Boeing B-17F was also the first Flying Fortress to be built in mass production. As well as the 2300 aircraft built by Boeing, Vega of Burbank, California built a further 500 aircraft and Douglas a further 605 B-17S at Long Beach California.

The most famous aircraft of this type was the B-17F-10-BO built by Boeing. It was delivered on 15 July 1942 and went into service with the 324<sup>th</sup> Bomber Squadron of the 91<sup>st</sup> Bomber Group in Basingstow, England. Her crew named her „Memphis Belle“ after the girl friend of her pilot Lt Robert K. Morgan. She achieved fame as a result of officially being the first bomber of the US Army Air Force to have survived 25 missions in Europe. She became the star of a Hollywood propaganda film from William Wyler which appeared in the cinemas in 1943. It was in reality however the B-17F-25-BO „Hell's Angels“ (41-24577) of the 365<sup>th</sup> Bomber Squadron, 305<sup>th</sup> Bomber Group which achieved this record on 13<sup>th</sup> May 1943. The „Memphis Belle“ however flew her 25th mission during an attack on the German U-Boat Base at Lorient in France on 17th May 1943. After this mission the „Memphis Belle“ and her crew were recalled to the USA in order to use their popularity to advertise for the emission of War Bonds and to increase the moral of workers in the American War factories.

Before and during its tour of the USA the „Memphis Belle“ received many changes to her appearance. In particular the crew's names were applied at a later date. The modeller therefore has the choice of many alternative liveries with this kit.

The „Memphis Belle“ is the oldest remaining B-17. After the War she was „bought“ by the city of Memphis and erected as a monument in the open, which was not particularly good for the aircraft's condition. The last remaining original designs and markings were lost during this „restoration“. On 29th September 2004 the National Museum of the USAF from invoked its ownership rights and ordered the return of the „Memphis Belle“ to Wright-Patterson Air Base. Here, the B-17 underwent a complete restoration whereby much emphasis was placed on the restoration of all the original markings. Today the „Memphis Belle“ is once again open to the public.

### Technical Data:

Wingspan:	31,63m (103ft 9ins)
Length:	22,78m (74ft 9ins)
Height:	5,82m (19ft 1ins)
Engines:	4 x Wright Cyclone R-1820-97
Power Rating:	1 200hp
Emergency Power Rating:	1380hp
Power Rating at 25000ft:	1000hp
Empty Weight:	15876 kg (35007 lbs)
Maximum Take-off Weight:	29484 kg (65012 lbs)
Cruising Speed:	297km/h (184mph)
Maximum Speed:	526km/h (326mph)
Service Ceiling:	11734m (38500ft)
Armament:	8 x 453kg (1000 lbs) Bombs or up to 24 x 45,3kg (100 lbs) Bombs 13 X 12.7mm Cal Machine Guns
Crew:	10

Forst hergestellt und im Eigentum von Revell GmbH & Co. KG. Weitere rechtliche Nachahmungen werden gerichtlich verfolgt.  
 Ce produsit este proprietate de a societate Revell GmbH & Co. KG. Toate utilizatiile sau duplicatiile frauduloase fara aprobare de la societate sunt interzise.  
 Modelado y en propiedad de Revell GmbH & Co. KG. Imitaciones ilicitas seran perseguidas por la ley.  
 Forma prodotta da la Revell GmbH & Co. KG. e di proprietate della stessa impresa, la quale procederà legalmente contro ogni imitazione abusiva.  
 Malli da Revell GmbH & Co. KG. valmistama ja omalustava. Laittoaan kopioituihin tuliaan puurtamaan oikeudellisiin toimin.  
 Formen er produsert og eies av Revell GmbH & Co. KG. Etterligning uten tillatelse vil bli gjerdstand for rettslig forligning.  
 Produccia i prava vlasnosto, firmy Revell GmbH & Co. KG. Nisagajine podrablanje jest zabranjeno pod odgovornostu nasovna sagoda.  
 Model, Revell GmbH & Co. KG. firmesinin mülkiyeti altında imal edilmiştir. Kanuna aykırı taklifler mahkemeye takip edilecektir.  
 A forma előállítása és a tulajdonjog círközése a Revell GmbH & Co. KG. A jogellenes utánozások és hamisításokért bíróságiag üldözök, üldözök.

Mould manufactured by and property of Revell GmbH & Co. KG. Illegal imitations are subject to prosecution.  
 Vorm vervaardigd door en eigendom van Revell GmbH & Co. KG. Onrechtmatige nabootsingen worden gerechtelijk vervolgd.  
 Formas produzidas e de propriedade da Revell GmbH & Co. KG. Copias não autorizadas serão processadas, unicamente como determinadas na lei.  
 Modellen tillverkad av och tillhör Revell GmbH & Co. KG. All kopiering beivras enligt lagen om upphovsrätt.  
 Formen er framstillet af Revell GmbH & Co. KG. som også for ejendommen. Lovstridige efterligninger sagdes.  
 Modelle valmistama ja omalustava. Laittoaan kopioituihin tuliaan puurtamaan oikeudellisiin toimin.  
 Formen er produsert og eies av Revell GmbH & Co. KG. Etterligning uten tillatelse vil bli gjerdstand for rettslig forligning.  
 Produccia i prava vlasnosto, firmy Revell GmbH & Co. KG. Nisagajine podrablanje jest zabranjeno pod odgovornostu nasovna sagoda.  
 Model, Revell GmbH & Co. KG. firmesinin mülkiyeti altında imal edilmiştir. Kanuna aykırı taklifler mahkemeye takip edilecektir.  
 A forma előállítása és a tulajdonjog círközése a Revell GmbH & Co. KG. A jogellenes utánozások és hamisításokért bíróságiag üldözök, üldözök.





# Benötigte Farben / Used Colors

Benötigte Farben  
Required colours

Peintures nécessaires  
Benodigde kleuren

Pinturas necesarias  
Tintas necessárias

Colori necessari  
Arvânda fârgeri

Tarvittavat värit  
Du trenger følgende farger

Nødvendige farger  
Необходимые краски

Potrebne barvy  
Απαιτούμενα χρώματα

Gerekli renkler  
Potrebne barvy

Szükséges színek  
Potrebne barve

## A

farngrün, seidenmatt 360  
green, silky-matt  
vert fougère, satiné mat  
varengroen, zijdemat  
verde helecho, mate seda  
verde feto, fosco sedoso  
verde felce, opaco seta  
ormbunksgrön, sidenmatt  
saniaisenvihreä, silkinhimmeä  
bregnegrøn, silkematt  
зелен. папоротник, шелк.-матовый  
zielony paproć, jedwabisto-matowy  
πράσινο φτέρης, μεταξωτό ματ  
egreitti otu yesilli, ipek mat  
kapradinová zelená, hedvábné mat.  
páfrányzöld, selyemmatt  
paprot zelena, svila mat

## B

anthrazit, matt 9  
anthracite grey, matt  
anthracite, mat  
antraciet, mat  
antracita, mate  
antracite, fosco  
antracite, opaco  
antracit, matt  
antrasiitti, himmeä  
koksgrå, mat  
antrasitt, matt  
антрацит, матовый  
antracyt, matowy  
ανθρακί, ματ  
antrasit, mat  
antracit, matná  
antracit, matt  
tamno siva, mat

## C

grau, matt 57  
grey, matt  
gris, mat  
grijs, mat  
gris, mate  
cinzento, fosco  
grigio, opaco  
grå, matt  
harmaa, himmeä  
grå, mat  
grå, matt  
серый, матовый  
szary, matowy  
γκρι, ματ  
grå, mat  
šedá, matná  
szürke, matt  
siva, mat

## D

rost, matt 83  
rust, matt  
rouille, mat  
roest, mat  
orin, mate  
ferrugine, fosco  
color ruginne, opaco  
rost, matt  
ruoste, himmeä  
rust, matt  
rust, matt  
ржавчина, матовый  
rdzawy, matowy  
χρώμα σκουριάς, ματ  
ras rengi, mat  
rezavá, matná  
rozsdá, matt  
rjava, mat

## E

aluminium, metallic 99  
aluminium, metallic  
aluminium, métallique  
aluminium, metallic  
aluminio, metalizado  
aluminio, métallico  
aluminio, metallic  
alumiini, metallikiilto  
aluminium, metallik  
aluminium, metallic  
алюминиевый, металлический  
aluminium, metalliczny  
ολουμίνιου, μεταλλικό  
aluminium, metallik  
aluminium, metallik  
aluminium, metallik

## F

90 %  
Gelboliv, matt 42 +  
Yellow olive, matt  
Olive jaunâtre, mat  
Geelolijf, mat  
Amarillo oliva, mate  
Amarelo-oliva, mate  
Giallo oliva, opaco  
Guloliv, matt  
Oliivinkeltainen, matta  
Gul oliven, mat  
Guloliven, matt  
Желто-оливковый, матовый  
Oliivkovožółty, matowy  
Κίτρινο λαδί, ματ  
Sary zeytin yesilli, mat  
Sárgás olajzöld, matt  
Žlutoolivová, matná  
Rumenoolivna, brez leska

## G

10 %  
gelb, matt 15  
yellow, matt  
jaune, mat  
geel, mat  
amarillo, mate  
amarelo, fosco  
giallo, opaco  
gul, matt  
keltainen, himmeä  
gul, mat  
gul, matt  
желтый, матовый  
žółty, matowy  
κίτρινο, ματ  
sari, mat  
žlutá, matná  
sárga, matt  
rumena, mat

## H

feuerrot, seidenmatt 330  
fiery red, silky-matt  
rouge feu, satiné mat  
rood helder, zijdemat  
rojo fuego, mate seda  
vermelho vivo, fosco sedoso  
rosso fuoco, opaco seta  
eldród, sidenmatt  
tulpurainen, silkinhimmeä  
íród, silkematt  
огненно-красный, шелк.-матовый  
szewrony ognisty, jedwabisto-mat.  
κόκκινο φωτιάς, μεταξωτό ματ  
ateş kırmızı, ipek mat  
ohnivě červená, hedvábné matná  
tűzpiros, selyemmatt  
ogenj rdeča, svila mat

## H

gelb, matt 15  
yellow, matt  
jaune, mat  
geel, mat  
amarillo, mate  
amarelo, fosco  
giallo, opaco  
gul, matt  
keltainen, himmeä  
gul, mat  
gul, matt  
желтый, матовый  
žółty, matowy  
κίτρινο, ματ  
sari, mat  
žlutá, matná  
sárga, matt  
rumena, mat

## I

eisen, metallic 91  
steel, metallic  
coloris fer, métallique  
ijzerkleurig, metallic  
ferroso, metalizado  
ferro, metallico  
ferro, metallico  
järnfärg, metallic  
teräksenväriäinen, metallikiilto  
jern, metallik  
jern, metallic  
стальной, металл  
żelazo, metaliczny  
σιδηρού, μεταλλικό  
demir, metalik  
železná, metaliza  
vas, metáll  
železna, metalik

## J

60 %  
ocker, matt 88 +  
ochre brown, matt  
ocre, mat  
oker, mat  
ocre, mate  
ocre, fosco  
ocra, opaco  
ockra, matt  
okra (keltamulta), himmeä  
okker, mat  
oker, mat  
окра, матовый  
ochra, matowy  
ώχρα, ματ  
koyu kavunıci, mat  
okrově žlutá, matná  
okker, matt  
oker, mat

## K

40 %  
braun, matt 85  
brown, matt  
brun, mat  
bruin, mat  
castanho, fosco  
marone, opaco  
brun, matt  
ruskea, himmeä  
brun, mat  
brun, matt  
коричневый, матовый  
brązowy, matowy  
καφέ, ματ  
kahverengi, mat  
barna, matt  
rjava, mat

## M

70 %  
eisen, metallic 91 +  
steel, metallic  
coloris fer, métallique  
ijzerkleurig, metallic  
ferroso, metalizado  
ferro, metallico  
ferro, metallico  
järnfärg, metallic  
teräksenväriäinen, metallikiilto  
jern, metallik  
jern, metallic  
стальной, металл  
żelazo, metaliczny  
σιδηρού, μεταλλικό  
demir, metalik  
železná, metaliza  
vas, metáll  
železna, metalik

## N

30 %  
anthrazit, matt 9  
anthracite grey, matt  
anthracite, mat  
antraciet, mat  
antracita, mate  
antracite, fosco  
antracite, opaco  
antracit, matt  
antrasiitti, himmeä  
koksgrå, mat  
antrasitt, matt  
антрацит, матовый  
antracyt, matowy  
ανθρακί, ματ  
antrasit, mat  
antracit, matná  
antracit, matt  
tamno siva, mat

## P

beige, matt 89  
beige, matt  
beige, mat  
beige, mat  
beige, mate  
beige, fosco  
beige, opaco  
beige, matt  
beige, himmeä  
beige, mat  
beige, matt  
бежевый, матовый  
beżowy, matowy  
μπεζ, ματ  
bej, mat  
bézová, matná  
bézs, matt  
bež (slonova kost), mat

## R

weiß, matt 5  
white, matt  
blanc, mat  
wit, mat  
blanco, mate  
branco, fosco  
bianco, opaco  
vit, matt  
valkoinen, himmeä  
hvid, matt  
hvit, matt  
белый, матовый  
biały, matowy  
λευκό, ματ  
beyaz, mat  
bilá, matná  
fehér, matt  
bela, mat

## S

Hellgrau, matt 76  
Light grey, matt  
Gris clair, mat  
Lichtgrijs, mat  
Gris claro, mate  
Cinzento-claro, mate  
Grigio chiaro, opaco  
Ljusgrå, matt  
Vaaleanharmaa, matta  
Lysegrå, mat  
Lysgrå, matt  
Светло-серый, матовый  
Jasnoszary, matowy  
Γκρι ανοιχτό, ματ  
Açik gri, mat  
Viágosszürke, matt  
Svætte šedivá, matná  
Svetlosiva, brez leska

## T

Dunkelgrün, matt 39  
Dark green, matt  
Vert foncé, mat  
Donkergroen, mat  
Verde oscuro, mate  
Verde-escuro, mate  
Verde scuro, opaco  
Mörkgrön, matt  
Tummanvihreä, matta  
Mörkgrøn, matt  
Mörkgrøn, matt  
Темно-зеленый, матовый  
Ciemnozielony, matowy  
Πράσινο σκούρο, ματ  
Koyu yesilli, mat  
Sötétzöld, matt  
Tmavomodrá, matná  
Temnozelená, brez leska

## U

helloliv, matt 45  
light olive, matt  
olive clair, mat  
olijf-licht, mat  
aceluma, mate  
oliva claro, fosco  
oliva chiaro, opaco  
ljusoliv, matt  
vaalean oliivi, himmeä  
lysoliv, mat  
lys oliven, matt  
светло-оливковый, матовый  
jasnooliwk., matowy  
ανοιχτό χακί, ματ  
açik zeytinli, mat  
svætteolivová, matná  
világos olív, matt  
svetlo oliva, mat

## V

grau, seidenmatt 374  
grey, silky-matt  
gris, satiné mat  
grijs, zijdemat  
gris, mate seda  
cinzento, fosco sedoso  
grigio, opaco seta  
grå, sidenmatt  
harmaa, silkinhimmeä  
grå, silkematt  
grå, silkematt  
серый, шелковисто-матовый  
szary, jedwabisto-matowy  
γκρι, μεταξωτό ματ  
grå, ipek mat  
šedá, hedvábné matná  
szürke, selyemmatt  
siva, svila mat

## X

schwarz, glänzend 7  
black, gloss  
noir, brillant  
zwart, glansend  
negro, brillante  
preto, brilhante  
nero, lucente  
svart, blank  
musta, kiiltävä  
sort, skinnende  
sort, blank  
черный, блестящий  
czarny, blyszczący  
μαύρο, γυαλιστερό  
siyah, parlak  
černá, lesklá  
fekete, fényes  
črna, bleskajoča



Schwarzen Faden benutzen  
Use black thread  
Employer le fil noir  
Gebruik zwarte draad  
Utilizar hilo color negro  
Utilizar fio preto  
Usare filo nero  
Använd svart tråd  
Käytä mustaa lankaa  
Benyt en sort  
Bruk svart  
Использовать черные нитки  
Użyć czarnej nici  
χρησιμοποιείστε την καφέ μούρου  
Kahverengi siyah iplik kullanın  
Použit černé vlákno  
barna fekete fonalat kell használni  
Uporabljati črni nit



Loch bohren  
Make a hole  
Faire un trou  
Maak een gat  
Practicar un taladro  
Perfurar  
Fare un foro  
Borra hål  
Poraa reikä  
Der bores et hul  
Bor hull  
Просверлить отверстие  
wyciercić otwór  
ανοίξτε τρύπα  
Delik açın  
Vyvrtat diru  
lyukat fürni  
Narediti lukinjo

Nicht enthalten  
Not included  
Non fourni  
Behoort niet tot de levering  
No incluido  
Non compresi  
Não incluído  
Ikke medsendt  
Ingår ej  
Ikke inkluderet  
Eivät sisälly  
Δεν ομπεριλαμβάνεται  
Не содержится  
Nem tartalmazza  
Nie zawiera  
Ni vsebovano  
İçerisinde bulunmamaktadır  
Neni obsaženo

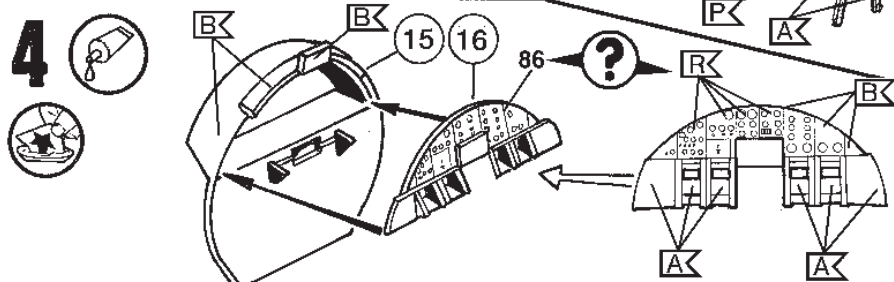
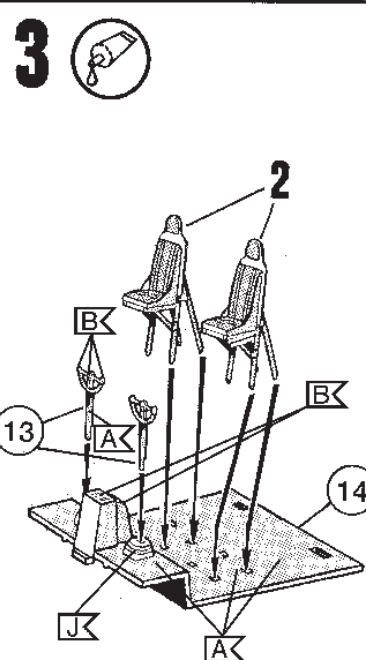
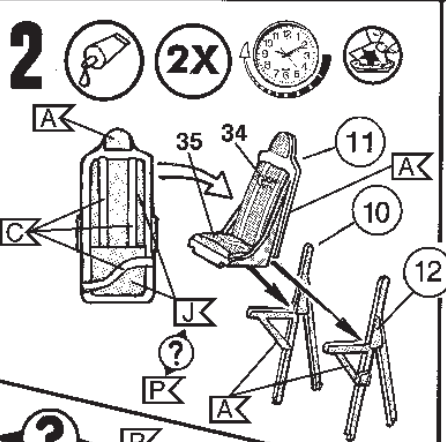
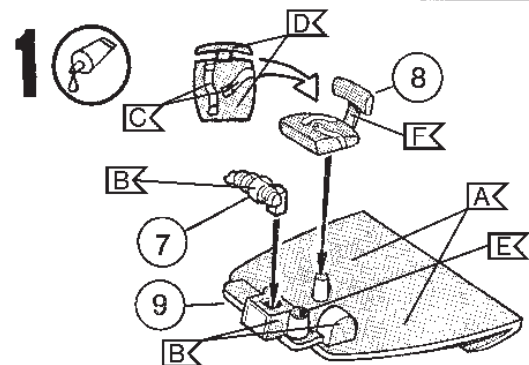
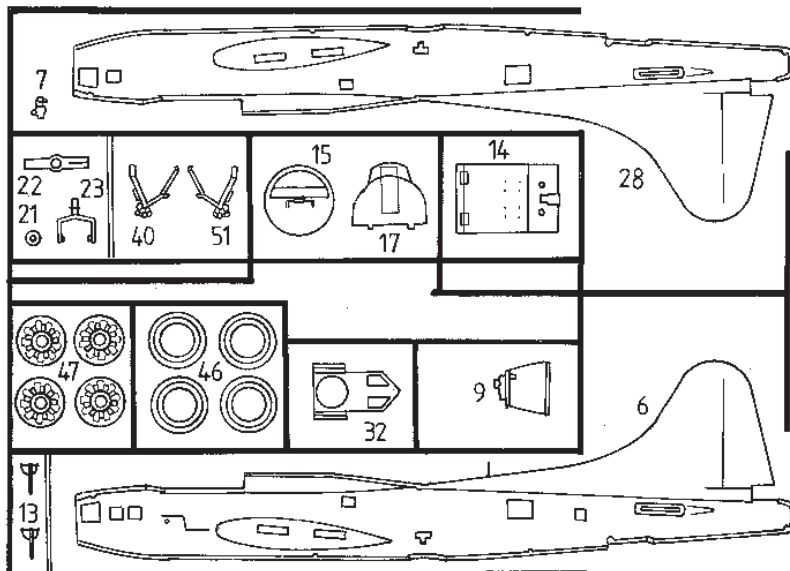
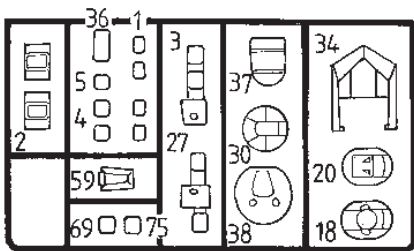
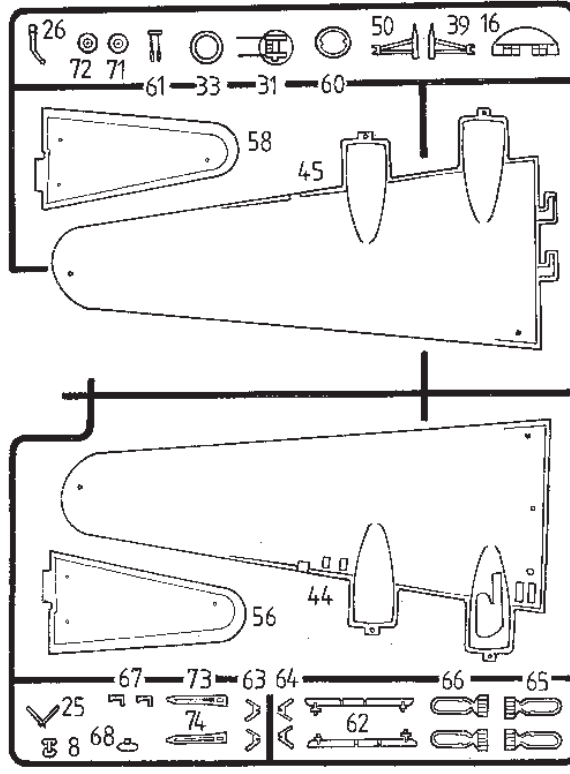
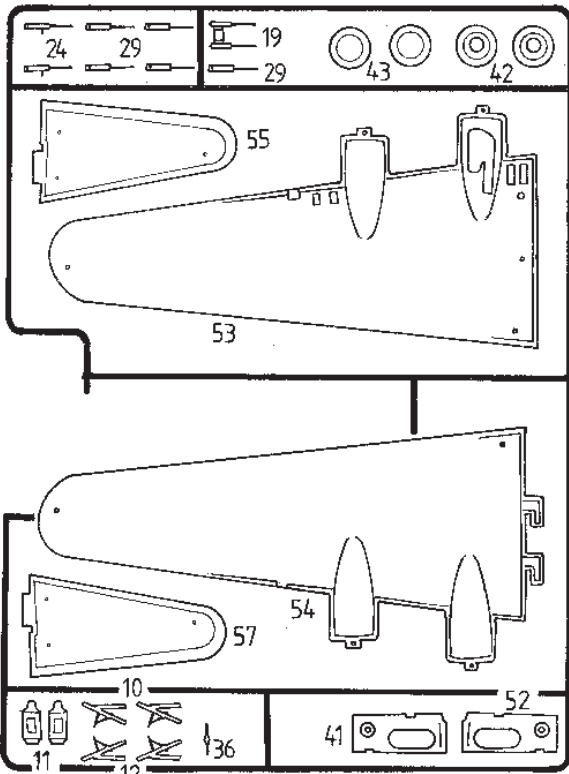

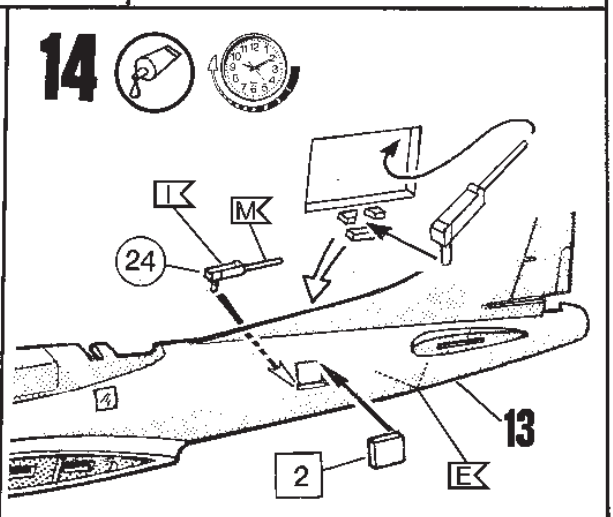
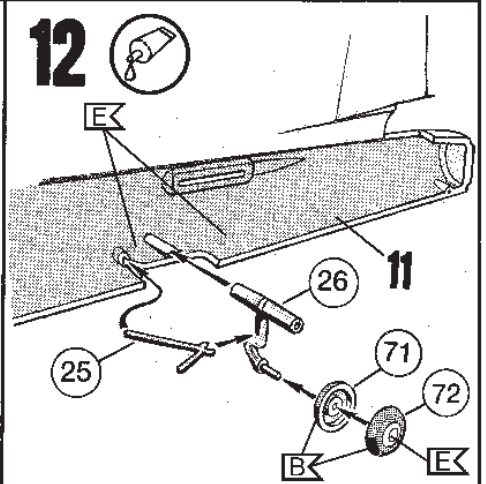
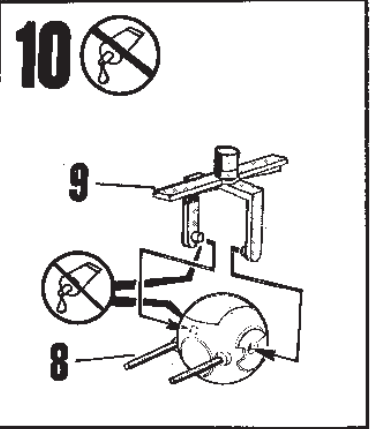
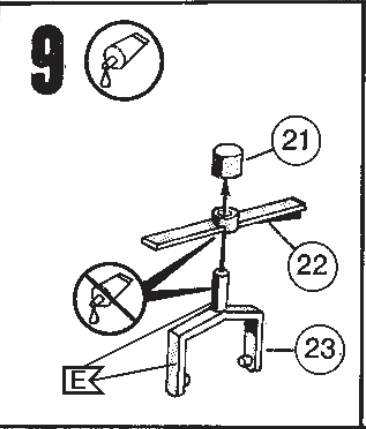
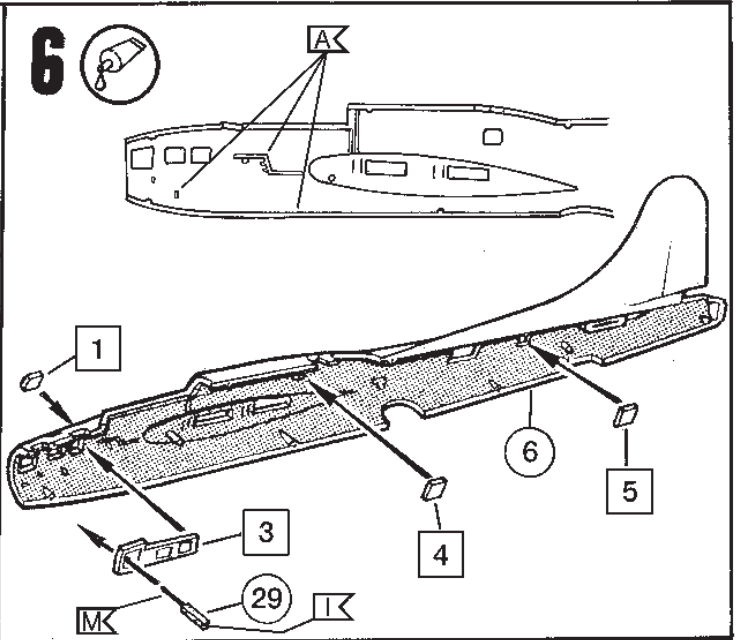
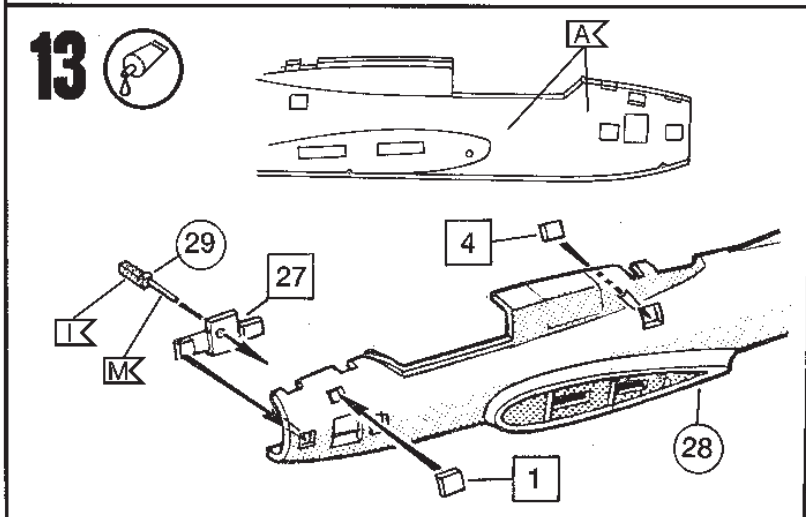
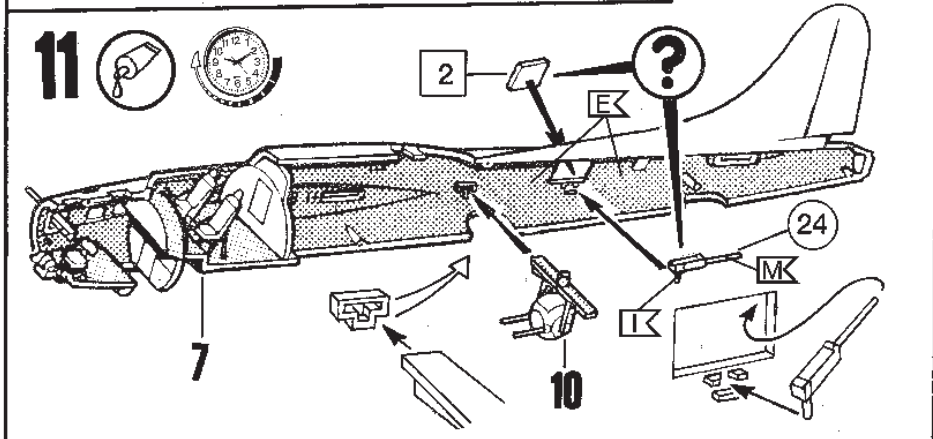
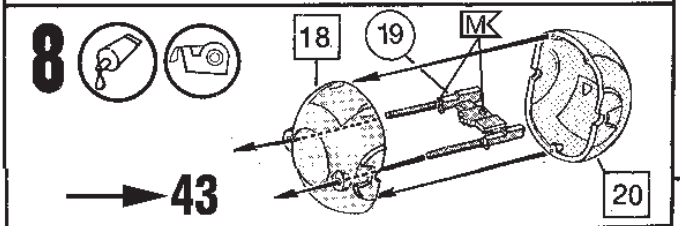
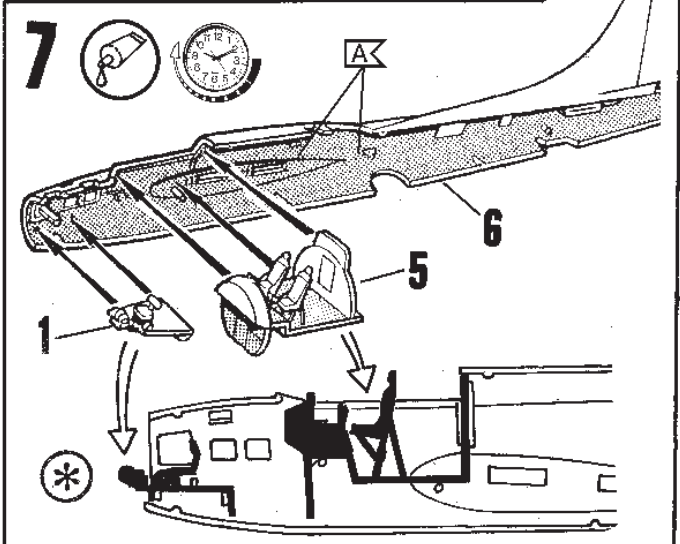
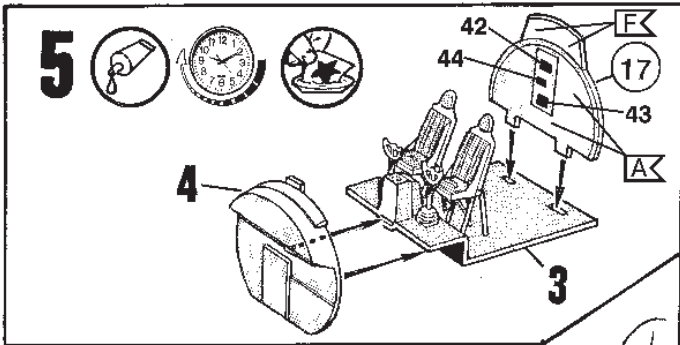

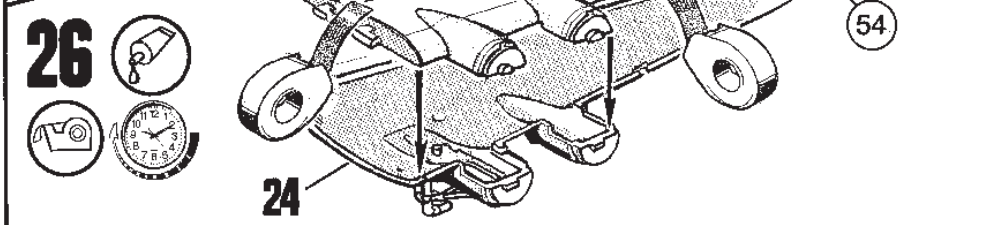
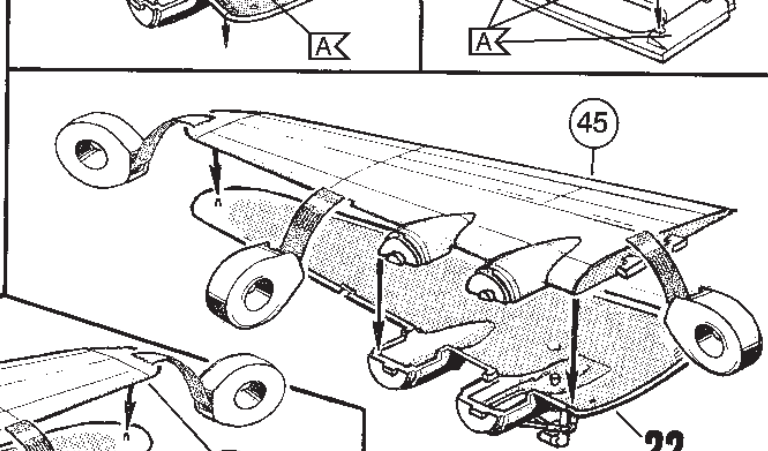
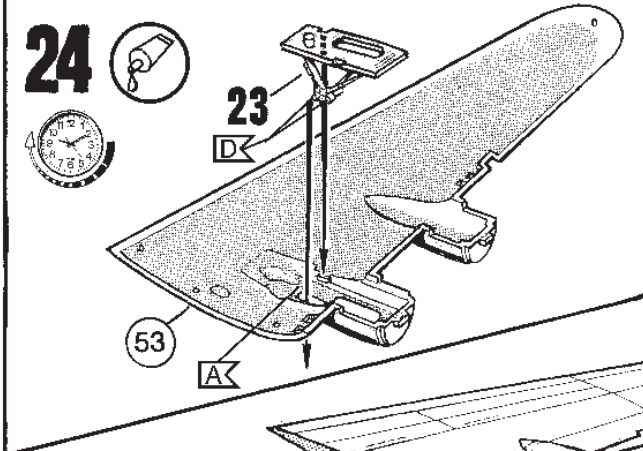
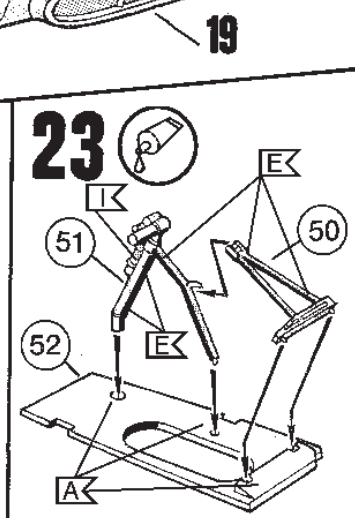
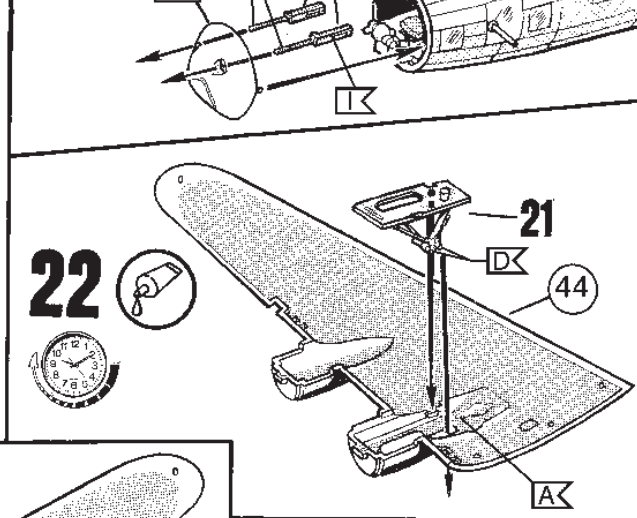
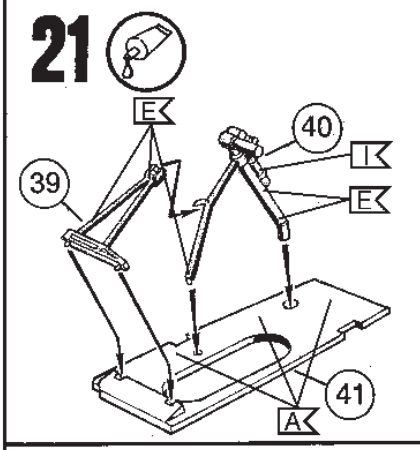
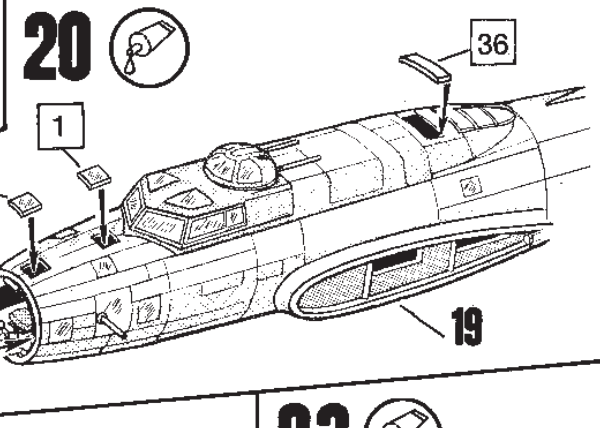
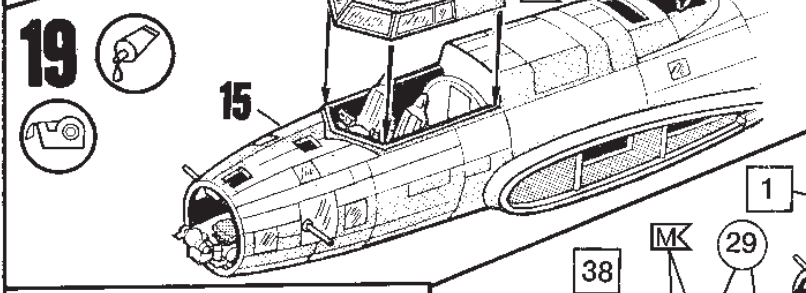
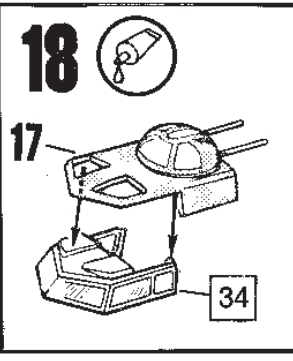
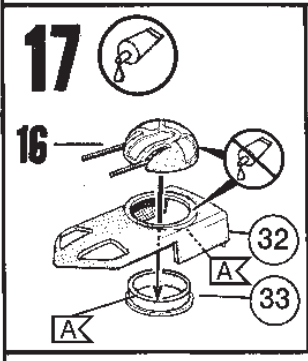
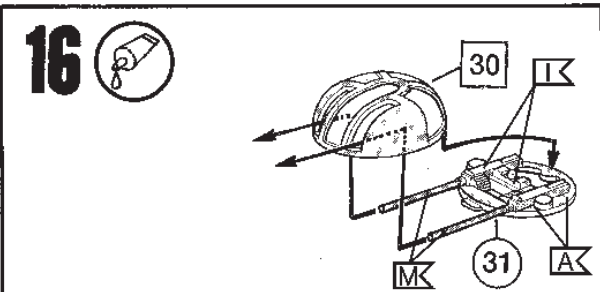
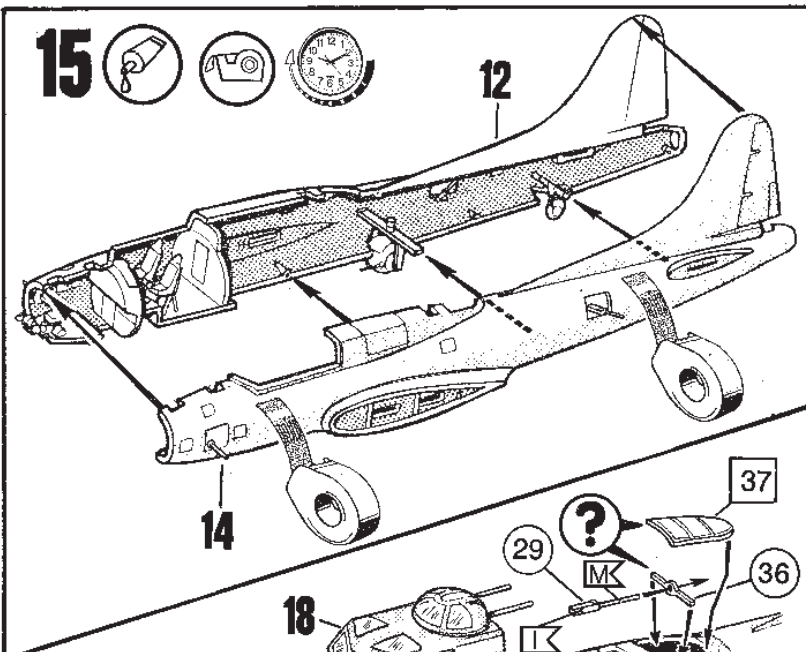

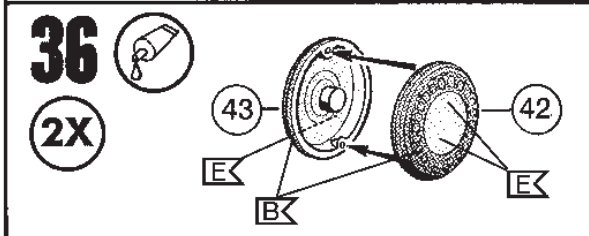
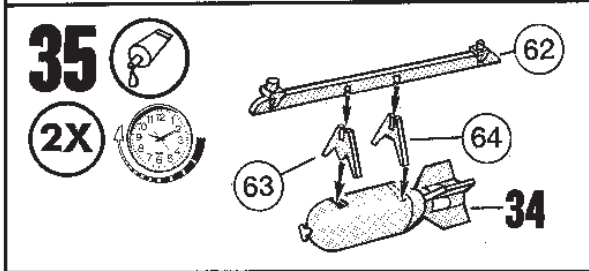
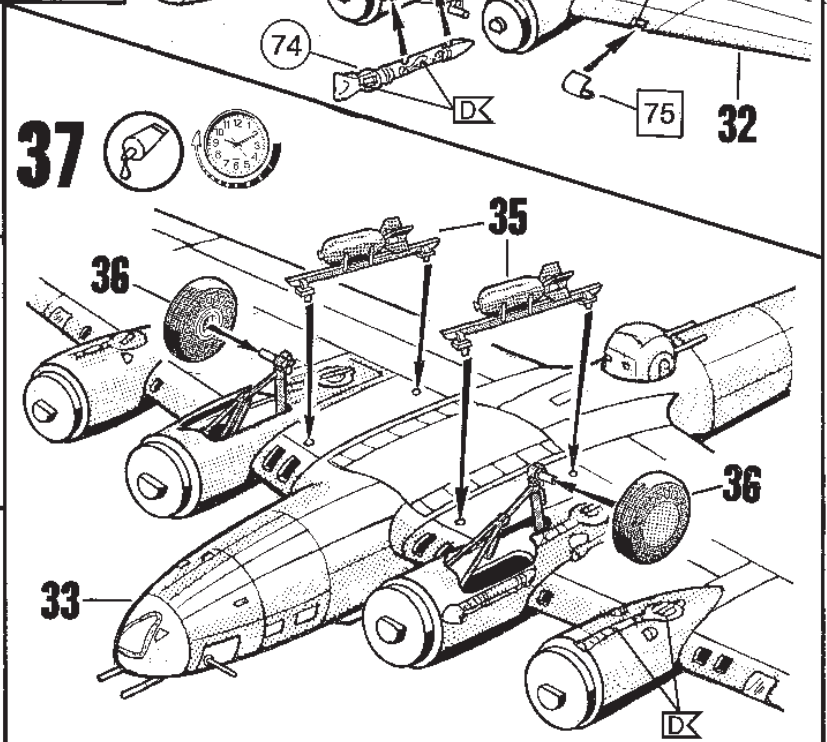
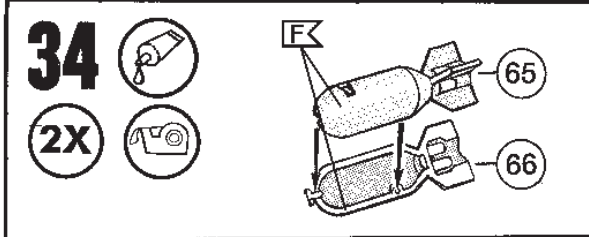
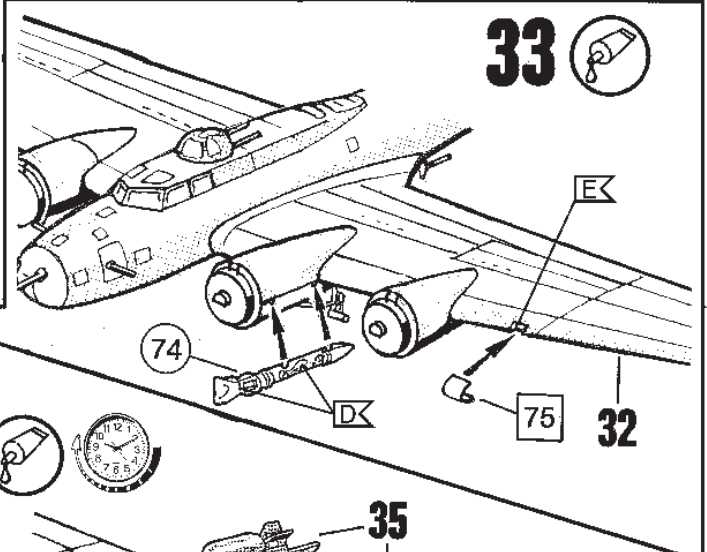
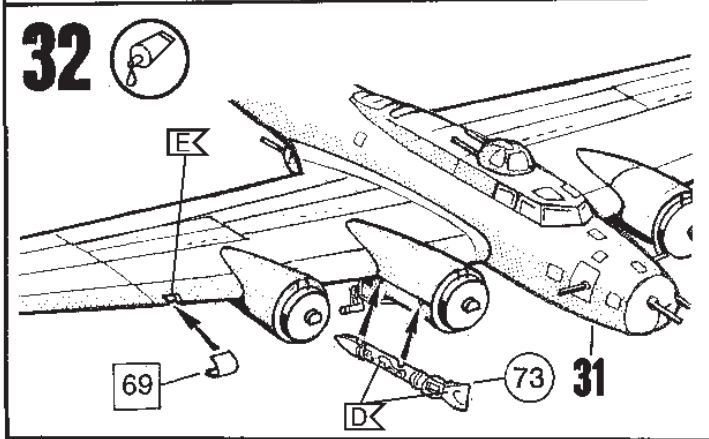
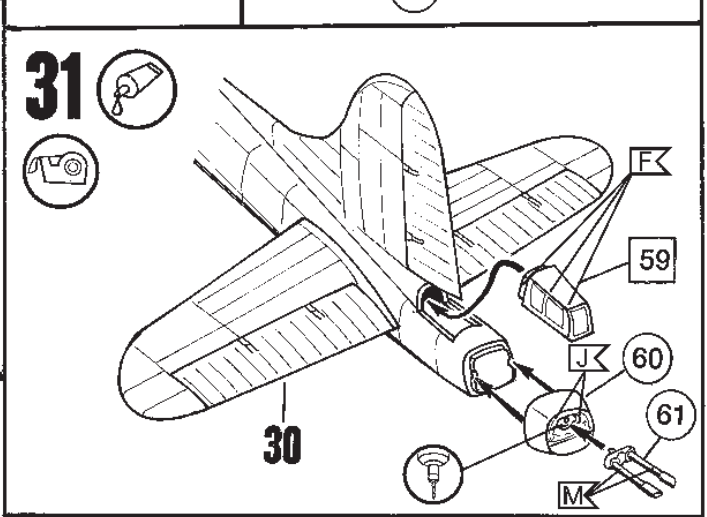
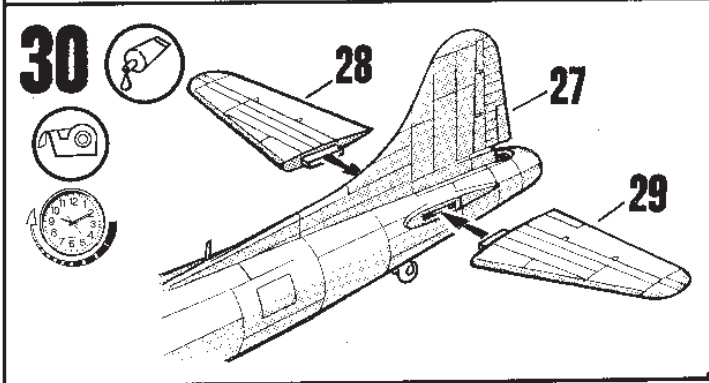
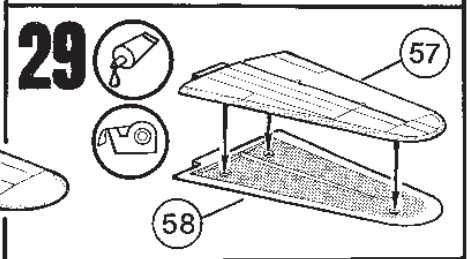
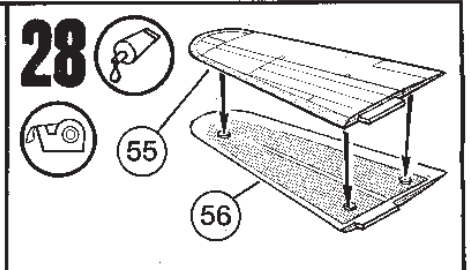
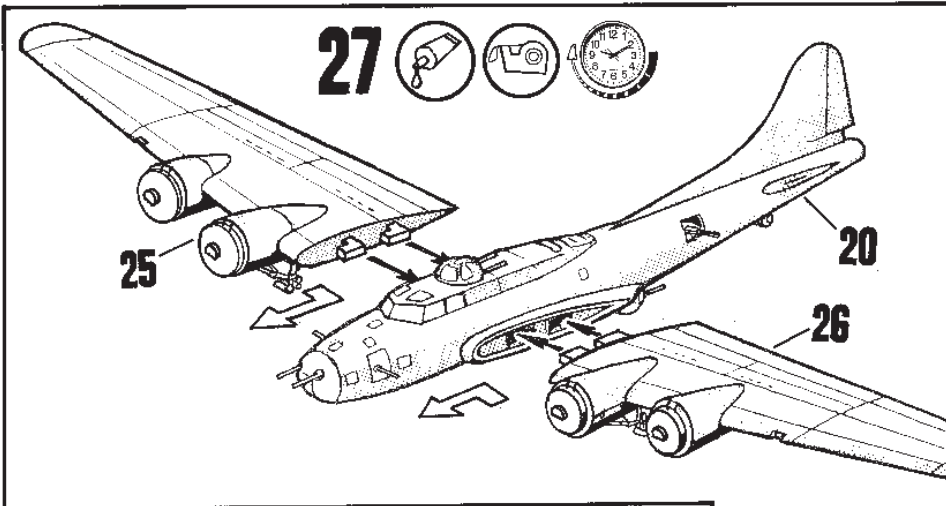



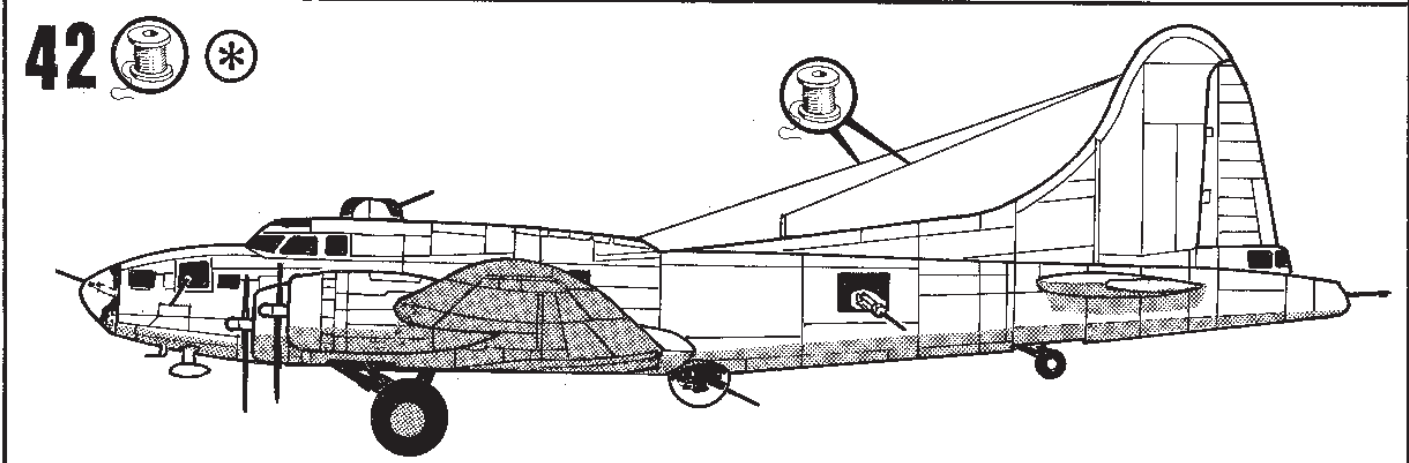
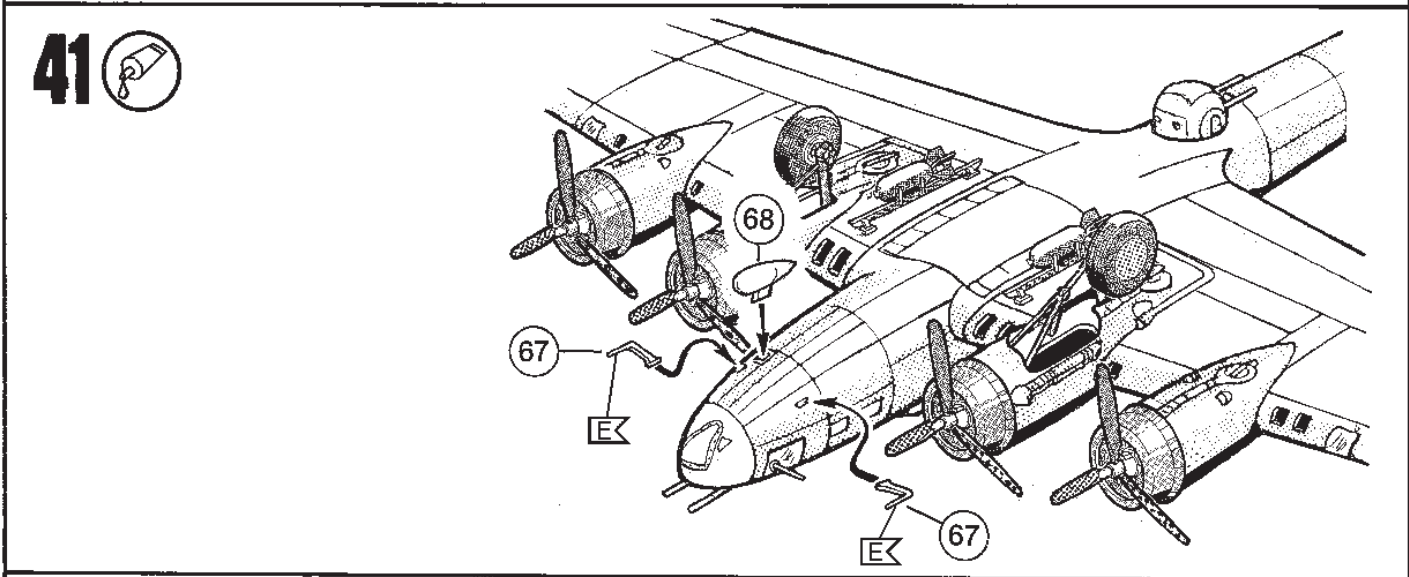
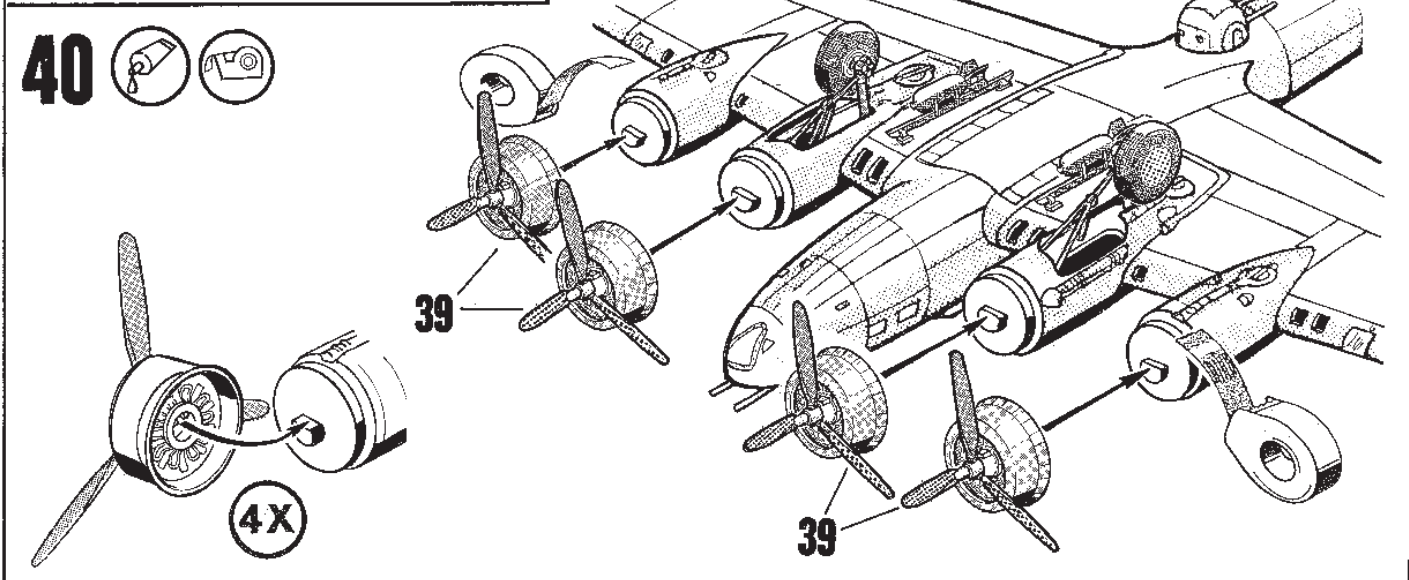
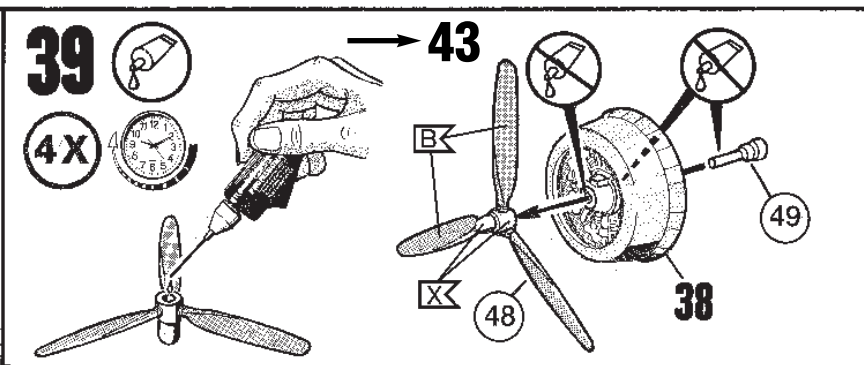
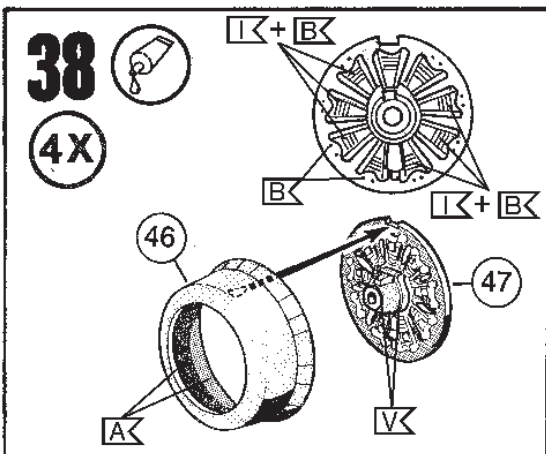

# 43

**Boeing B17F-10-BO Flying Fortress**  
 „Memphis Belle“; of 324th Bomb Squadron,  
 91st Bomb Group; Bassingbourn, U.K.; May 1943

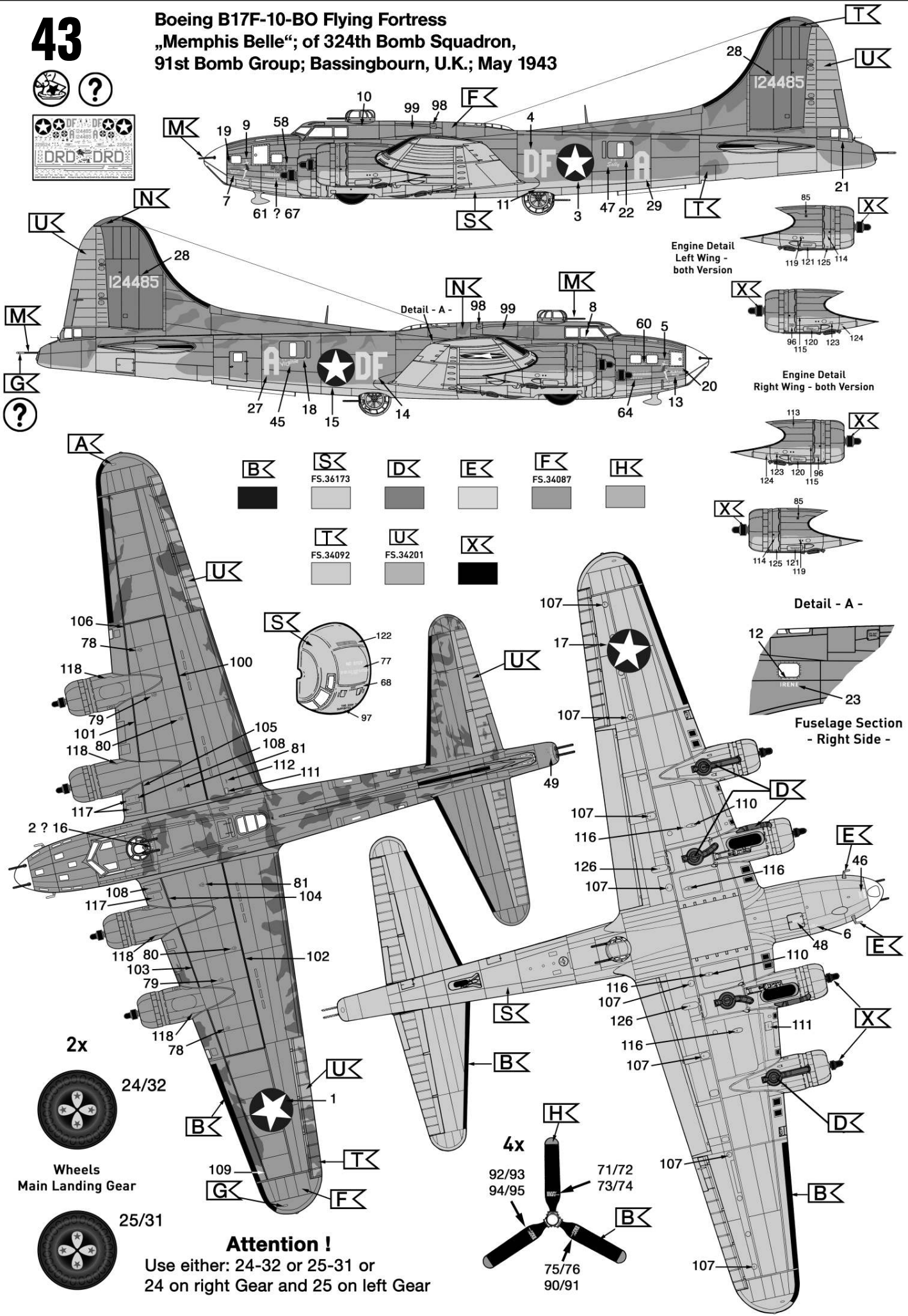

Engine Detail  
 Left Wing -  
 both Version

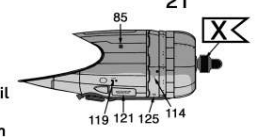

Engine Detail  
 Right Wing - both Version

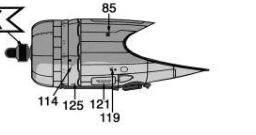
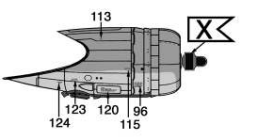
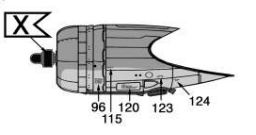

Detail - A -

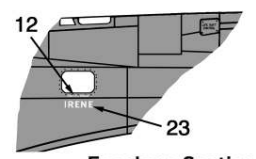

Fuselage Section  
 - Right Side -

<b>B</b>	<b>S</b> FS.36173	<b>D</b>	<b>E</b>	<b>F</b> FS.34087	<b>H</b>
<b>T</b> FS.34092	<b>U</b> FS.34201	<b>X</b>			

2x



24/32

Wheels  
 Main Landing Gear



25/31

**Attention !**

Use either: 24-32 or 25-31 or  
 24 on right Gear and 25 on left Gear

4x

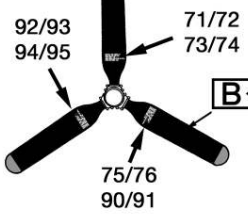

# 44

## Boeing B-17F-55-BO Flying Fortress of 423rd Bomb Squadron, 306th Bomb Group at Thurleigh, U.K., Spring 1943

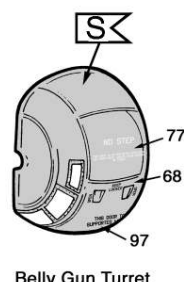
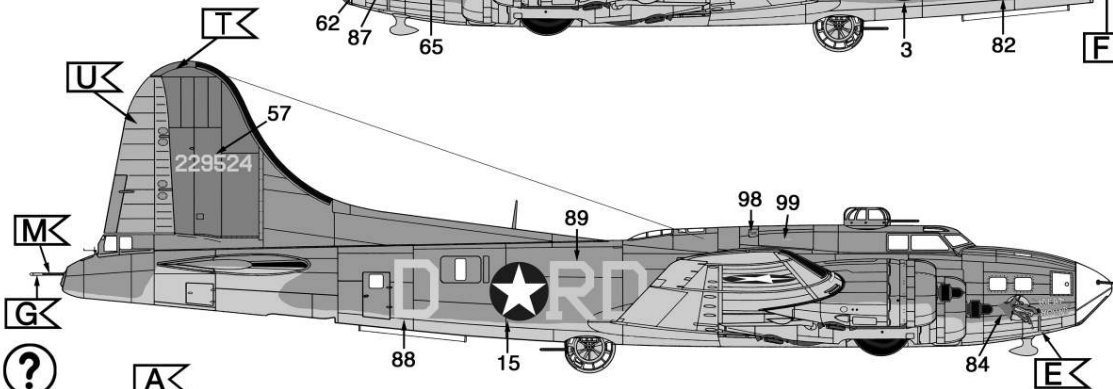
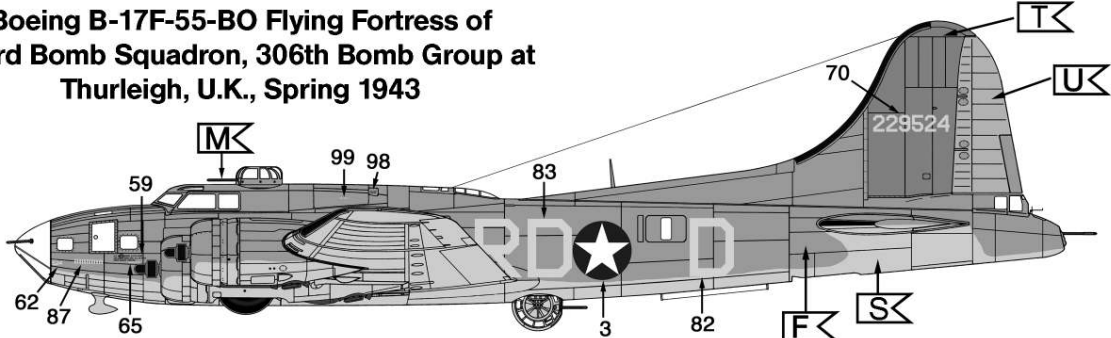

<b>B</b>	<b>S</b> FS.36173	<b>D</b>	<b>E</b>	<b>F</b> FS.34087	<b>H</b>
<b>T</b> FS.34092	<b>U</b> FS.34201	<b>X</b>			

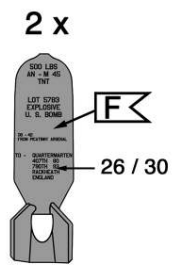
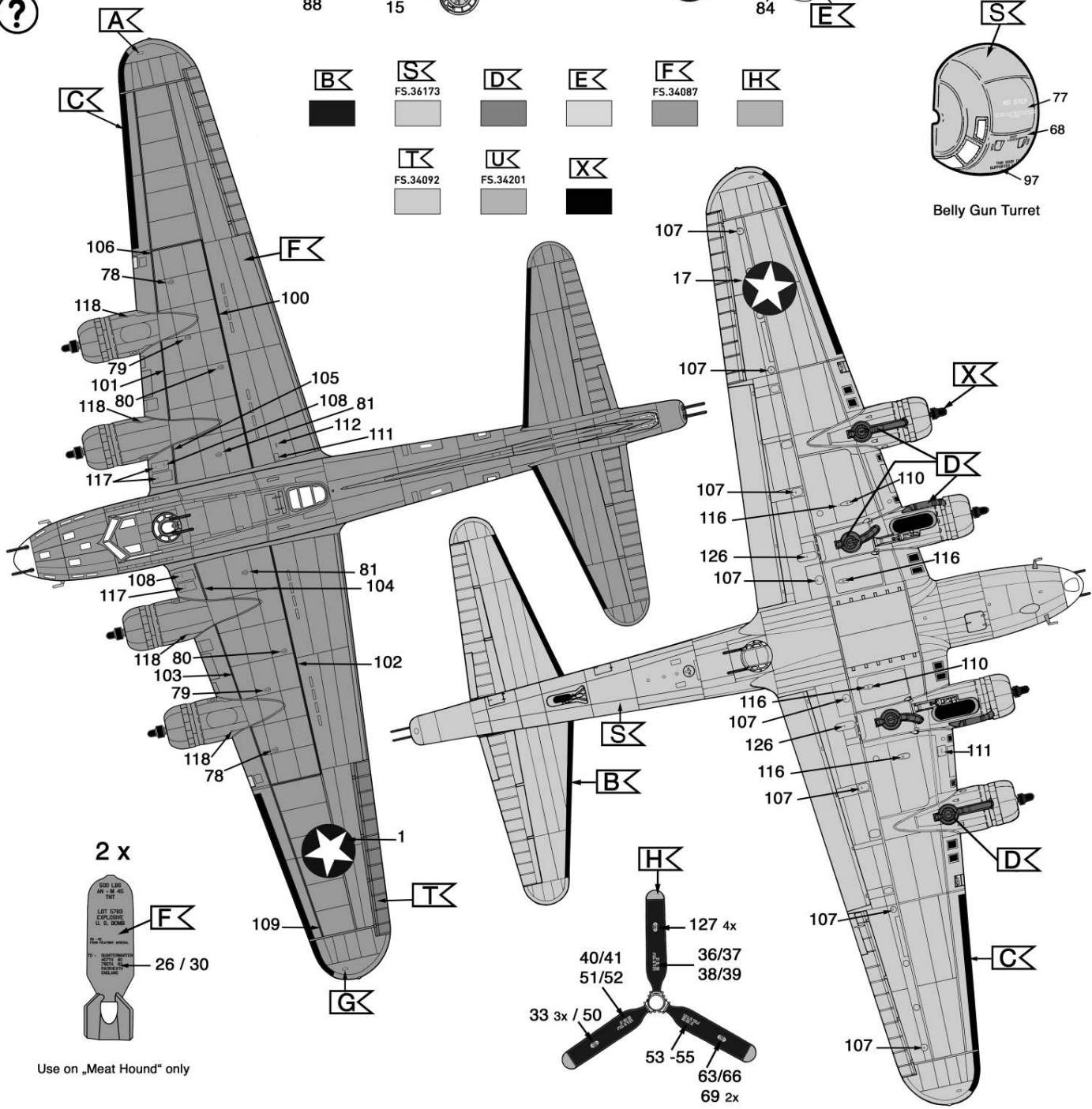

Use on „Meat Hound“ only